



Hawai'i State Department of Education
Ka 'Oihana Ho'ona'auao o ke Aupuni Hawai'i



RING: FREE CYBERSECURITY CURRICULUM

Debasis Bhattacharya, JD, DBA
UH Maui College
debasisb@hawaii.edu
maui.hawaii.edu/cybersecurity

AGENDA

- Cybersecurity at UHMC
 - Cybersecurity across disciplines and student populations
- NSA/DHS Center for Academic Excellence (CAE)
 - UHWO, UHMC, HonCC, LeeCC
- RING Curriculum
- Pathways from RING to UH
- Cybersecurity Workforce Update

CYBERSECURITY EDUCATION - TRADITIONAL

- Certificates in Cybersecurity
 - Low Level - Intro, Network+, Security+
 - Higher Level - Ethical Hacking, Forensics
- Internships
 - Government, banks, utilities
- Baccalaureate Degree
 - Applied Business and Info Tech
 - Cybersecurity courses are embedded
- Cyber competitions and Workshops
 - NSA GenCyber, US AFA CyberPatriot
- Supported by NSF Grants
 - ATE Program Award# 1700562



CYBERSECURITY EDUCATION - ACROSS DISCIPLINES & SEGMENTS

- Cybersecurity education cuts across various segments
 - Community College program disciplines
 - Gender
 - Minorities
 - Background - high schools, professionals, returning veterans etc
 - Various Industries
 - Accounting, Hospitality, Law Enforcement, Utility, Tourism etc.
- One size education does not fit all types of students!

4



CYBERSECURITY EDUCATION - ACROSS STUDENT POPULATION

- Focus on students from a variety of backgrounds
 - Women
 - Minorities
 - Veterans
 - Working Professionals
 - High School Students
 - Remote students who rely totally on distance education
 - Economically disadvantaged
 - Low math/science proficiency
 - Non-technical
 - Non-traditional
 - Not interested in Cybersecurity as a career!



DIVERSE CYBERSECURITY EDUCATION - OVERALL APPROACH

- Obtain administration and other institutional support
- Identify key faculty leaders in key disciplines
- Engage faculty and students
 - Guest Lectures in classes
- Engage employers who will hire students with cyber skills
 - Hotels, banks, tourism industry, law enforcement
- Identify one or two existing courses in each discipline
 - Explore cybersecurity modules that can be embedded
- Hold workshop with faculty from various disciplines
 - Stipend helps!
- Create modules and help faculty member teach it!



National Security Agency/Central Security Service

Search NSA



[About](#) [Press Room](#) [Careers](#) [History](#)

National Centers of Academic Excellence in Cybersecurity



Bachelor of Applied Science

Information Security and Assurance

Overview

The concentration in Information Security and Assurance is the first of its kind at a public institution in Hawai'i and the Pacific. UH West O'ahu, in cooperation with University of Hawai'i Community Colleges, state and federal law enforcement agencies, state security officials, and local businesses, developed an expansive security education program covering a wide variety of technical and managerial aspects within the field.



Center for Cybersecurity Education and Research (CCER)

The University of Hawaii Maui College (UHMC) has been designated as a National Center of Academic Excellence (CAE) in Cyber Defense Education (CDE) through academic year 2024 for the Bachelor of Applied Science (BAS) in Applied Business and Information Technology (ABIT) Degree. For details about the National Centers of Academic Excellence (CAE) click [here](#).





Certificate of Achievement in Information Assurance

Courses selected for this certificate meet the two-year core knowledge unit requirements for a college to become recognized as a [National Center of Academic Excellence in Cyber Defense Two-Year](#) (CAE2Y). This program, which is sponsored by the NSA and DHS, recognizes colleges that have met their standard of academic excellence in Information Assurance education. Honolulu Community College is currently recognized as a CAE2Y.



CYBERSECURITY CENTER



Leeward Community College's **Cybersecurity Center** showcases a variety of cybersecurity-related programs and resources available to students and faculty.

On August 28, 2018, the College received notification that is officially designated as a **National Center of Academic Excellence in Cyber Defense Education Two-Year (CAE2Y)**. This program recognizes collegiate institutions which have met their standards of excellence in Cyber Defense education.

The institutional award was established by the National Security Agency (NSA) and the Department of Homeland Security (DHS), with the support of the National Science Foundation (NSF) and CyberWatch for community colleges that have established a robust information assurance program.



RING Update

UAH RING Core Team



Jesse Hairston
RING Director



Tania Williams
Pedagogical Expert



Katherine MacGilvray
Program Coordinator



Ashley Mahoney
Student Org. Coord.



Karen Brown
RING Counselor



Anna Rodgers
RING Teacher



Amelia Adkins
RING Teacher



Benjamin Cummins
RING Teacher



Jessica Pockrus
Instructional Support



Carolyn Sanderlin
Graphic Designer

RING Overview



Regions
Investing in the
Next
Generation

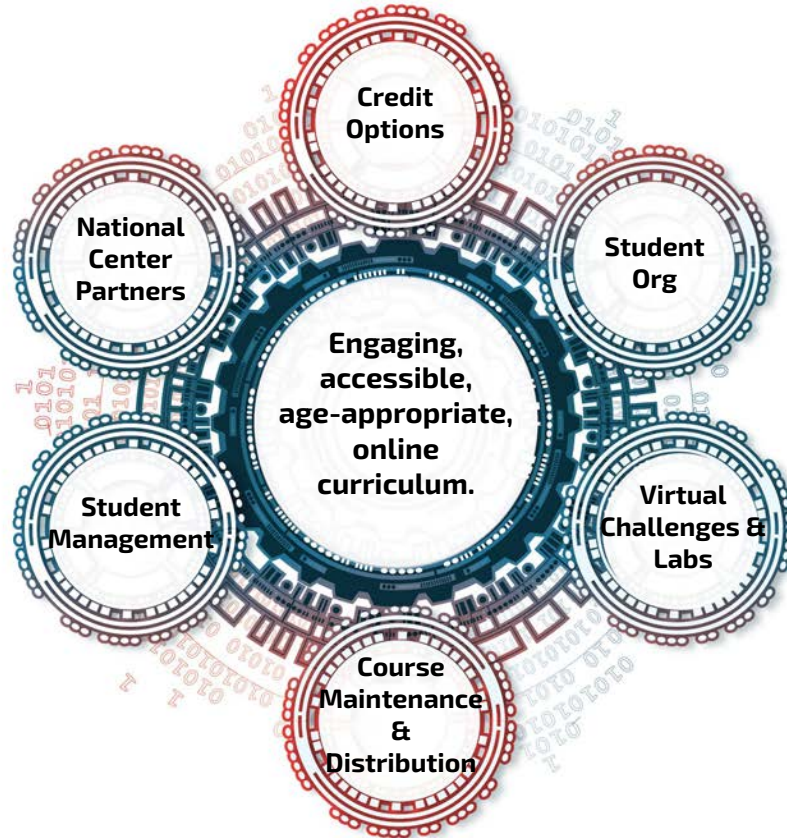

RING is...
Cybersecurity for
students without
access to a cyber
program.

- Rural
- Homeschool
- Under-resourced

Timeline Highlights

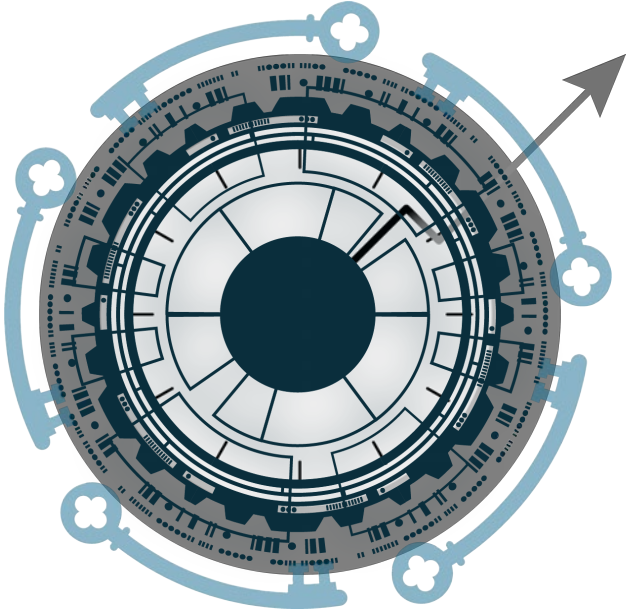

Fall 2020 - Summer 2022

Curriculum Development and Review

Fall 2021 - Spring 2022

RING Pilot Course

Fall 2022

Major Feedback/Reviews Implemented
Curriculum Released and Distributed

Fall 2022 - Present

Full RING Courses Launched
Ongoing Curriculum Maintenance
Continued Distribution
EPNC Collaborations

Instructing RING

- 1) **EPNC Centralized Instruction** - seasoned RING teachers teach target demographic students in a proven virtual experience
- 2) **EPI Regional Courses** - EPI partners provide meaningful RING experiences to local area students
- 3) **External Instruction** - students learn cybersecurity from their school teachers with access to RING

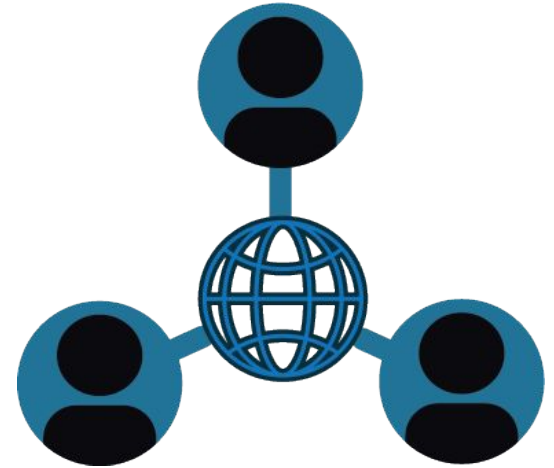

The Standards

Cybersecurity Curriculum Guidelines (CCG)

- Ethics
- Establishing Trust
- Ubiquitous Connectivity
- Data Security
- System Security
- Adversarial Thinking
- Risk
- Implications

“Guidelines created to encourage curriculum providers, teachers, and industry to create curriculum designed to inspire high school students to pursue a profession in cybersecurity, as well as develop thinkers with a cybersecurity mindset that will enhance any profession they pursue.”¹

Targeted Foundational CAE Knowledge Units

¹<https://cryptologicfoundation.org/what-we-do/educate/high-school-cybersecurity-curriculum-guidelines.html>

Curriculum Package

Lesson Plans & Instructor Slides

Lesson Plan & Instructor Slides

Tuesday, Sep 22, 2020

Unit Timeline

Day 3: 3.1 Ubiquitous Connectivity

Standards and Objectives

3.1 EO The Internet is a large, globally distributed network that is divided into...

3.1.1 UD Students will explain how devices use layers to communicate across...

3.1.14 EX Networks carry two types of information, those that allow for the co...

CAE KUs

Lesson Delivery and Setup

Instructor will need a computer, access to the Internet, and a projector (or appropriate screen sharing software if virtual). Student activities can be completed on paper or digitally. Students will need access to the Internet for some activities.

Procedures

Warm Up Activity

Have students work with a partner to describe a grocery store. They might list things like the customers, the employees, the cash

Labs & Games



Visually-Rich Content

| Physical Layer | Logical Layer | Social Layer |
|-----------------------------|----------------------------|--------------------------|
| Geographic Components | Logical Network Components | Persona Components |
| Physical Network Components | | Cyber Persona Components |

Graphic Organizers

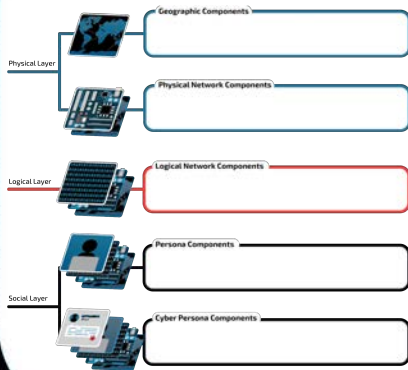

Assessments

Name: _____ Class: _____ Date: _____ ID: A

Classify the CIA Triad (Print)

Objective: I can categorize the CIA Triad.

Part 1: Drag and drop each part of the CIA Triad to match the scenario.

Confidentiality **Integrity** **Availability**

Fraudulent dollar bills.

Which part of the Triad does this scenario VIOLATE?

Glasses with a built-in microphone.

Which part of the Triad does this scenario VIOLATE?

A cell phone signal jammer.

Which part of the Triad does this scenario VIOLATE?

Name: _____ Class: _____ Date: _____ ID: A

Unit 11 Authentication and Identity Management

Multiple Choice

Identify the choice that best completes the statement or answers the question.

- This ties behavior to a specific user.
 - a. password
 - b. username
 - c. least privilege
 - d. multi-factor
- Which of the following is NOT a way to authenticate a user?
 - a. Something the user knows
 - b. Someone the user knows
 - c. Something the user is
 - d. Something the user has
- Which of the following is something the user does?
 - a. username
 - b. fingerprint
 - c. signature recognition
 - d. retina scan
- Which of the following is NOT a good password strategy?
 - a. Making a good password and using it over and over
 - b. Having a password that is easy to remember but difficult to guess
 - c. Having a password that is complex
 - d. Making a unique password for each account
- Which of the following is NOT a factor in password strength?
 - a. length
 - b. type of account
 - c. complexity
 - d. unpredictability
- Simon finds a helixicon that has a lock that is three numbers long (_____) what is the maximum number of tries it would take her to find the correct combination of the lock?
 - a. 10
 - b. 100
 - c. 1,000
 - d. 10,000
- Which password would take the longest to crack?
 - a. 123456
 - b. T!lk@17
 - c. apple!
 - d. qwerty
- Which of the following is an example of good password security?
 - a. changing passwords often
 - b. hiding the password underneath the keyboard
 - c. sharing your password with only your best friend
 - d. keeping your password the same as the default password

| | | | |
|---------------------------|---|-------------------------------|----------|
| Data Application | End user layer: program opens | HTTP, FTP, DNS, Telnet | Software |
| Data Presentation | Syntax Layer: Encrypt / Decrypt | SSH, IMAP, JPEG, MPEG | |
| Data Session | Sync & Send: Interhost communication | SQL, PAP, API's, Sockets | |
| Segments Transport | TCP & Flow Control: Communication & Reliability | TCP, UDP | Hardware |
| Packets Network | Packets: Path Determination & IP Addressing | IPv4, IPv6, IPsec, ICMP, IGMP | |
| Frames Data Link | Frames: MAC & LLC (Physical) Addressing | Ethernet, ARP, STP, PPP | |
| Bits Physical | Physical Structure: Media, Signal, & Digital Transmission | Coax, Fiber, Wireless | |

RING Canvas

RING Modules

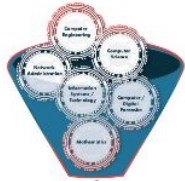

Cybersecurity Career

[Unit 0: Introduction](#)

[Content List](#)



[Unit 1: Ethics](#)

[Content List](#)



[Unit 2: Establishing Trust](#)

[Content List](#)



[Unit 3: Ubiquitous Connectivity](#)

[Content List](#)



[Unit 4: Data Security](#)

[Content List](#)



[Unit 5: Introduction to Python](#)
Programming

[Content List](#)



[Unit 6: System Security](#)

[Content List](#)



[Unit 7: Adversarial Thinking](#)

[Content List](#)



[Unit 8: Risk](#)

[Content List](#)



[Unit 9: Implications](#)

[Content List](#)

Labs and Games

Labs provide hands-on learning through an online portal.

Games map to Big Ideas that drive the primary learning objectives.

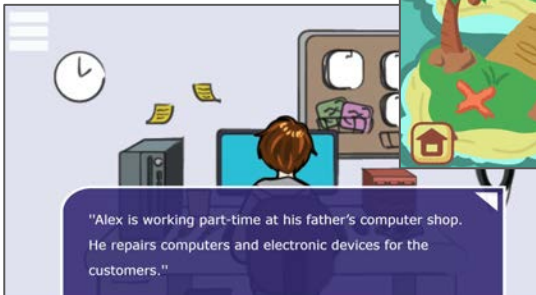

"Alex is working part-time at his father's computer shop. He repairs computers and electronic devices for the customers."



Asymmetric Practice

Name: _____
Date: _____
Period/Block: _____

Objectives:

Explain the relationship between public and private keys in asymmetric cryptography.

Apply an asymmetric cryptographic tool to accomplish confidentiality and integrity in a practical scenario.

Overview

RSA is a popular algorithm used for asymmetric cryptography. It can be used to generate public-private key pairs and both encrypt and decrypt information. You will explore RSA using a simple online tool to encrypt a message to your partner. In a future assignment, we will install and use a more realistic version of RSA.

Setup

1. This is a paired activity. Grab a partner and work together!
2. Both you and your partner visit the website: <https://www.javainuse.com/rsagenerator>
(Note: if the website is down, use the backup site: <https://www.codeusingjava.com/tools/rsa>)
3. You and your partner will need a way to copy and paste data back and forth (e.g., Zoom, Slack, email).

1. Key Generation

You and your partner will each generate your RSA public and private keys: click **Generate Keys**.

RSA Generate: Keys

This tool generates RSA public key as well as the private key of sizes - 512 bit, 1024 bit, 2048 bit, 3072 bit and 4096 bit with Base64 encoded. The generated private key is generated in PKCS#8 format and the generated public key is generated in X.509 format.

Lab Access

Netlabs offer virtual machines on any device.
Coastline Community College hosts Netlab access
for RING teachers across the country.

RING Netlab Access

- 18 teachers
- 12 states
- 350 students

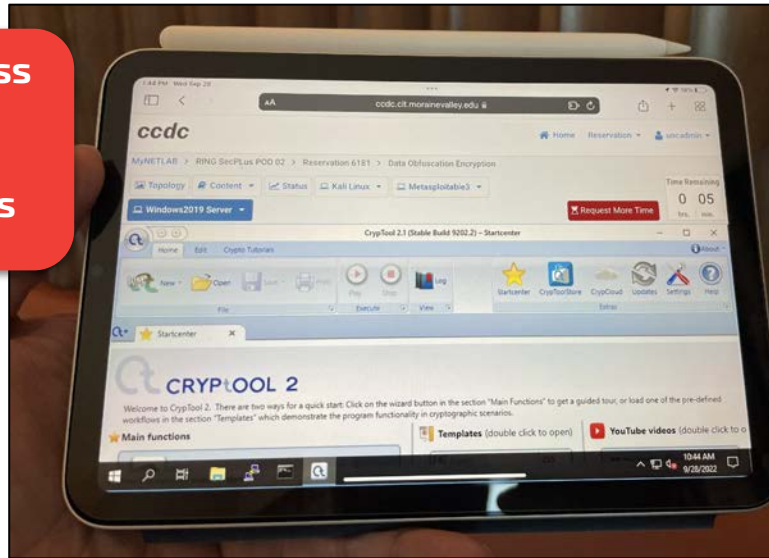

Competency Lab 3 – Hashing, Encryption, and Password Cracking

After your excellent work on the network, the agency is loaning you to help law enforcement to take down a ransomware group. As part of the sting operation, we have to send the file 'Meeting' from the StingOps folder located on Kali Linux desktop. We suspect that the group will try to change the contents of the message in-transit so your job is to make sure our agent inside has a way to verify the integrity of the document he receives.

1. Produce text file 'HASH' that can be sent via secure channel for verification purposes. Please make sure the file ONLY contain the SHA256 hash of the secret file (i.e., get rid of the file's name). Take a screenshot of the open HASH file.

Command: sha256sum <filename> | awk '{print \$1}' > HASH

```
student@kali-lite:~/Desktop/StingOps$ sha256sum Meeting | awk '{print $1}' > HASH
student@kali-lite:~/Desktop/StingOps$
```

2. Count the number of characters in the HASH file. Is the number correct? Why?
Command: wc -m HASH

```
student@kali-lite:~/Desktop/StingOps$ wc -m HASH
64
```

YES
SHA256 create 64-character hash

Excellent job. We sent the document and our agent already replied. For security purposes he used the polynstantiation strategy and sent multiple documents as part of the package. The documents, along with the hash file Verification we received through secure channel were saved to Reply folder on the Linux Kali desktop. We need your help to detect the correct document.

3. Please identify the correct document.

Command: sha256sum <file(s)> >> Candidates OR find -type f -exec sha256sum {} \; >> Candidates
grep -f <sent_hash_file> Candidates

Course Layout and Formatting

Assignments and lectures are grouped by week.

- Assignments open on Monday morning and are due the following Saturday at 6 p.m.
- Assignments in a unit can be accessed, submitted, or resubmitted through the end of the unit.

The front page of the course only contains the week's assignments and pertinent information for the course that week.

100% of students who completed an end-of-semester survey reported a score of 3 or above on the statement: "The class is organized in a way that I always know what is expected of me and can find all materials and resources easily."

Week of December 9 - December 13, 2022

Announcements

- Quick Access:
 - [NetLab Info](#)
 - [Guest Speaker Recordings](#)
 - [RING Student Org Information](#)
- There will be no class on January 16th.

[CLICK TO MAKE AN OFFICE HOURS APPOINTMENT](#)

[Unit 5: Introduction to Python Programming.](#)

[Optional For Fun Discussion Post: A Day in the \(Not\) Life](#)

Monday (1/13)

- [Activity: User-Defined Functions](#)

Tuesday (1/14)

- Lecture only

Wednesday (1/15)

- [Activity: Truth Table Sort](#)
- [Activity: Nested Conditionals](#)

Thursday (1/16)

- Lecture only

Friday (1/17)

- [Activity: Loops](#)



Student Contact & Engagement

Student contact is an ongoing priority. These efforts look like:

- Weekly announcements
- Monday missing work emails
- Office hours
- Personalized positive emails each semester
- Synchronous test review sessions
- Lectures involving props and personal examples relevant to the students
- “Fun” optional weekly discussion posts
- Frequent polls requesting student feedback on the course and adapting the course based on the suggestion

Of the students who responded to the end-of-semester poll, 45% specifically noted that they find the lectures helpful and engaging.

Parent Engagement & Contact

Parent engagement and contact occurs mostly through email.

- At least one positive email is sent to parents throughout the course of the RING course – Student emails have been very well received by parents and have helped to develop stronger rapport with the parents.
- Parent emails are sent for late work and/or an unresponsive student if the student is falling behind significantly or has been unresponsive for an extended period of time.
- Parent night

Assessment

Both formative and summative assessment is ongoing throughout the course.

- There are no late penalties for assignments
- Missing assignments are graded as a 40%
- Formative assessments can be resubmitted with corrections after grading so long as the correction shows a change in thinking and application of feedback
- One retake is allowed for each summative assessment, but the retake is different from the initial assessment

| Group | Weight |
|----------------------|--------|
| Graphic Organizers | 5% |
| Discussion Questions | 5% |
| Homework/Activities | 10% |
| Quizzes | 10% |
| Labs/Projects | 40% |
| Exams | 30% |
| Total | 100% |

The average overall grade for the class is a 92.8% and the average test score is 87.2%

Virtual Adaptations

Teaching in a virtual environment has unique challenges due to the varying schedules, needs, and learning styles of the students.

- Frequent student input and feedback is essential
- Being adaptable to the needs of the students

Adaptations

- Lightening workload
- Ample discussion posts, both graded and ungraded
- Catch-up opportunities beyond the course
- Flexibility in due dates and assignments

Teach with RING!

Teacher Curriculum Request Form



Educators* can gain full access to the curriculum package

- All Units available
- Gain access to virtual labs
- RING Student Org events
- Provide feedback

*Educators who request access must provide proof of their school/homeschool affiliation.



Enroll Students in RING!

Option A: Spring 2023 (single semester) Enroll in the RING course from January 2023 through May 2023.

Option B: Fall 2023 (single semester) Enroll in the RING course from August 2023 through December 2023.

Option C: Academic Year (2023-2024) Enroll in the RING course from August 2023 through May 2024.

Special Option: Summer 2023 (single semester) Enroll in the RING course from May 30 to August 3.

RING Website:

caecommunity.org/initiative/k12-ring

**Student
Enrollment
Request Form**



RING Centralized Course

74 students across the nation are enrolled in RING or have completed the course through the centralized program.

- Pilot course: 14 students completed
- 2022-23: 37 students participating
- Spring 2023: 23 enrolled

**"I just like it so much I can't stop myself from looking up more about the topic...this is probably my favorite class this year."
-RING Pilot Student**



RING Course Maintenance

An EPI curriculum review committee will be established to review:

- Formal processes for institutions, educators, and professionals to recommend RING edits
- Major changes to the RING course

RING updates and news will be shared with subscribers and EPIs for dissemination.

RING EPNC centralized splash page will summarize the program and updates.



RING Student Org

Students will receive entry to their own student organization.

- Connected to the online course
- Webinars
- Online discussion groups
- Mentorship
- Career pathway advice
- Certification guidance
- Other opportunities & activities

Students can complete a learning/community service portfolio to also be considered for the honor society.

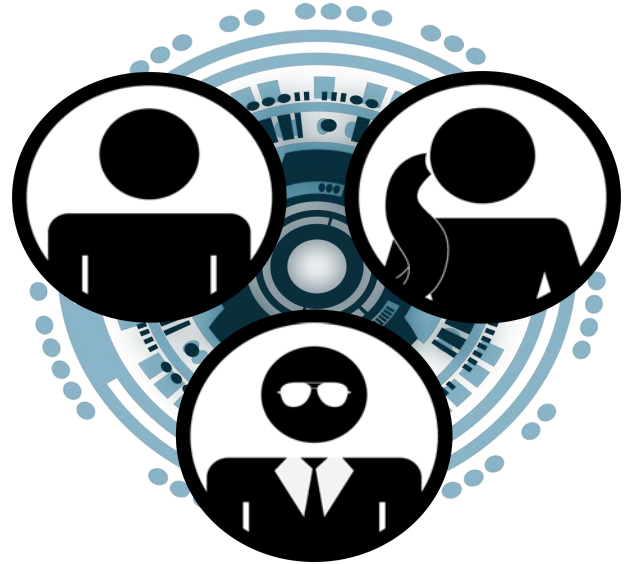

NICE Work Roles

NICE Work Roles are highlighted through RING student org events and guest presenters.



Systems Security Analyst RING 1



Northrup Grumman **Romell Foster**

Sr. Cyber System Engineer

IT Security While working for Jacobs Technology, Romell found a passion for Information Technology and Security.

Program Manager RING 2



UAH CCRE **Jesse Hairston**

Assistant Director

Certified Ethical Hacker Jesse works to expand cyber education by creating curricula and opportunities that are accessible to new learners.

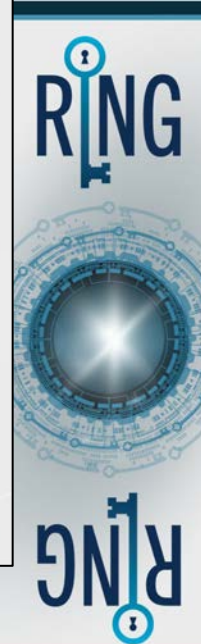

Pathways from RING to UHMC and other UHCCs

Certificate of Competence (CO) in Information Security (12 credits):

(All courses are taught completely online via the WWW)

- **ICS 101** – Digital Tools for an Information World (3 credits)...introduction to digital technology.
- **ICS 169** – Introduction to Information Security (3 credits)...covers 10 core areas of **ISC2**
- **ICS 184** – Introduction to Networking (3 credits)...covers CompTIA **Network+**
- **ICS 171** – Introduction to Computer Security (3 credits)...covers CompTIA **Security+**

Certificate of Achievement (CA) in Information Security (24 credits):

(All 4 courses required in the above Certificate of Competence, plus 4 below)

- **ICS 281** – Ethical Hacking (3 credits)...covers EC-Council **CEH**
- **ICS 282** – Digital Forensics (3 credits)...covers EC-Council **CHFI**
- **ENG 100 (or higher)** – English Composition I (3 credits)
- **MATH 103 (or higher)** – College Algebra (3 credits)

CYBERSECURITY SUPPLY/DEMAND HEAT MAP

- All
- Public Sector Data
- Private Sector...
- Total job openings

States

Metro Areas

Click on a state or MSA for more info

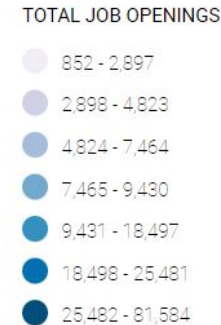
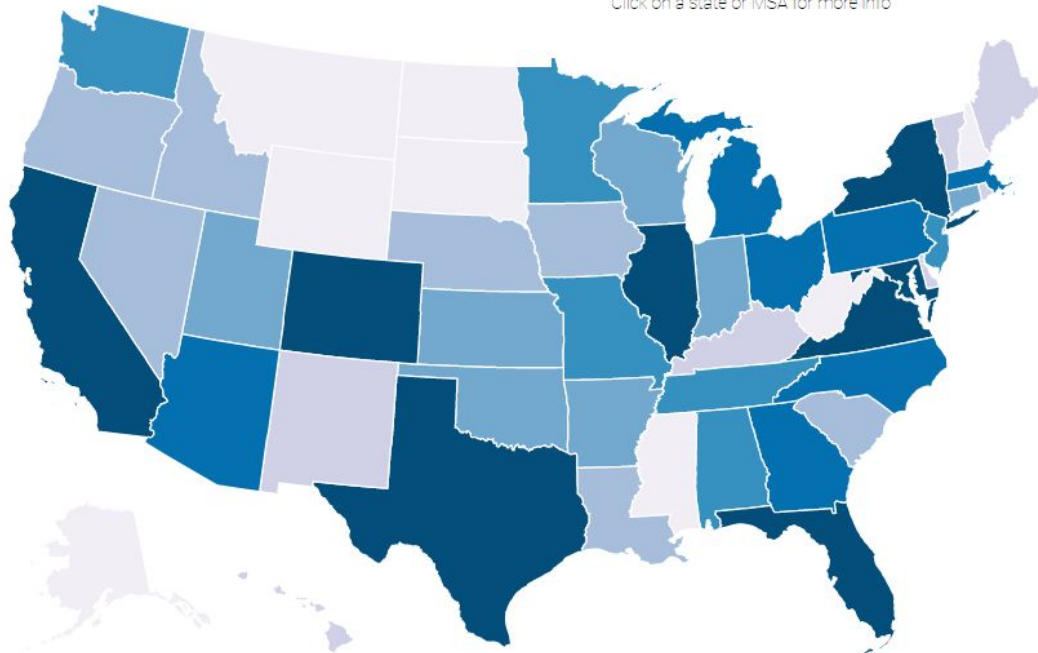

Share

Hawaii

TOTAL CYBERSECURITY JOB OPENINGS ⓘ

4,053



TOTAL EMPLOYED CYBERSECURITY
WORKFORCE ⓘ

6,340



SUPPLY/DEMAND RATIO ⓘ

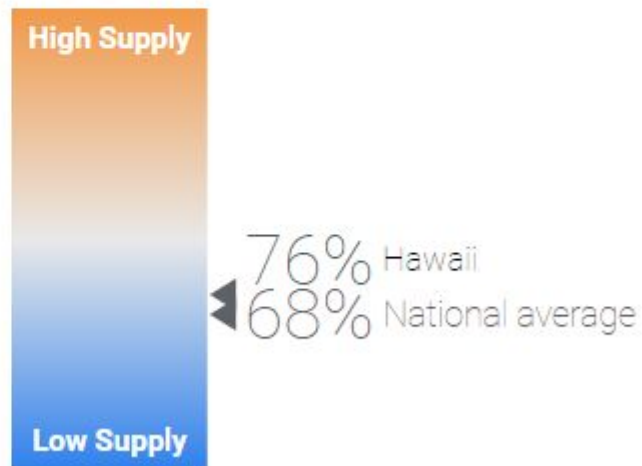

GEOGRAPHIC CONCENTRATION ⓘ

Very High

LOCATION QUOTIENT

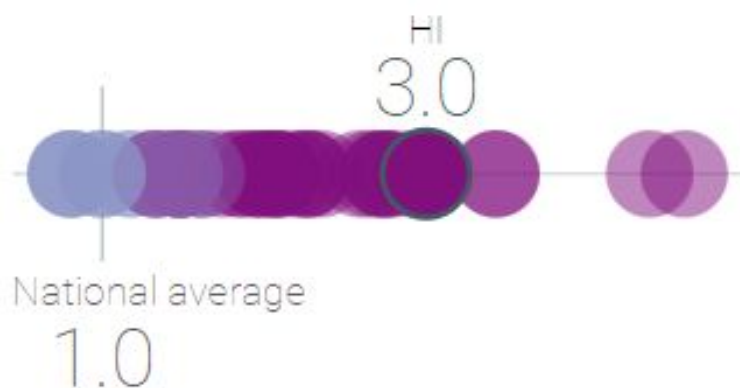

TOP CYBERSECURITY JOB TITLES ⓘ

- Network Engineer
- Cybersecurity Consultant
- Cybersecurity Analyst
- Software Developer
- Cybersecurity Manager
- Cybersecurity Specialist
- Systems Administrator
- Systems Engineer
- Penetration & Vulnerability Tester

JOB OPENINGS BY NICE CYBERSECURITY WORKFORCE FRAMEWORK CATEGORY

NICE



Notes: The NICE Workforce Categories are not mutually exclusive- one job could perform multiple roles within the framework. The data shown here are not intended to be aggregated.

↑ NICE - Operate & Maintain

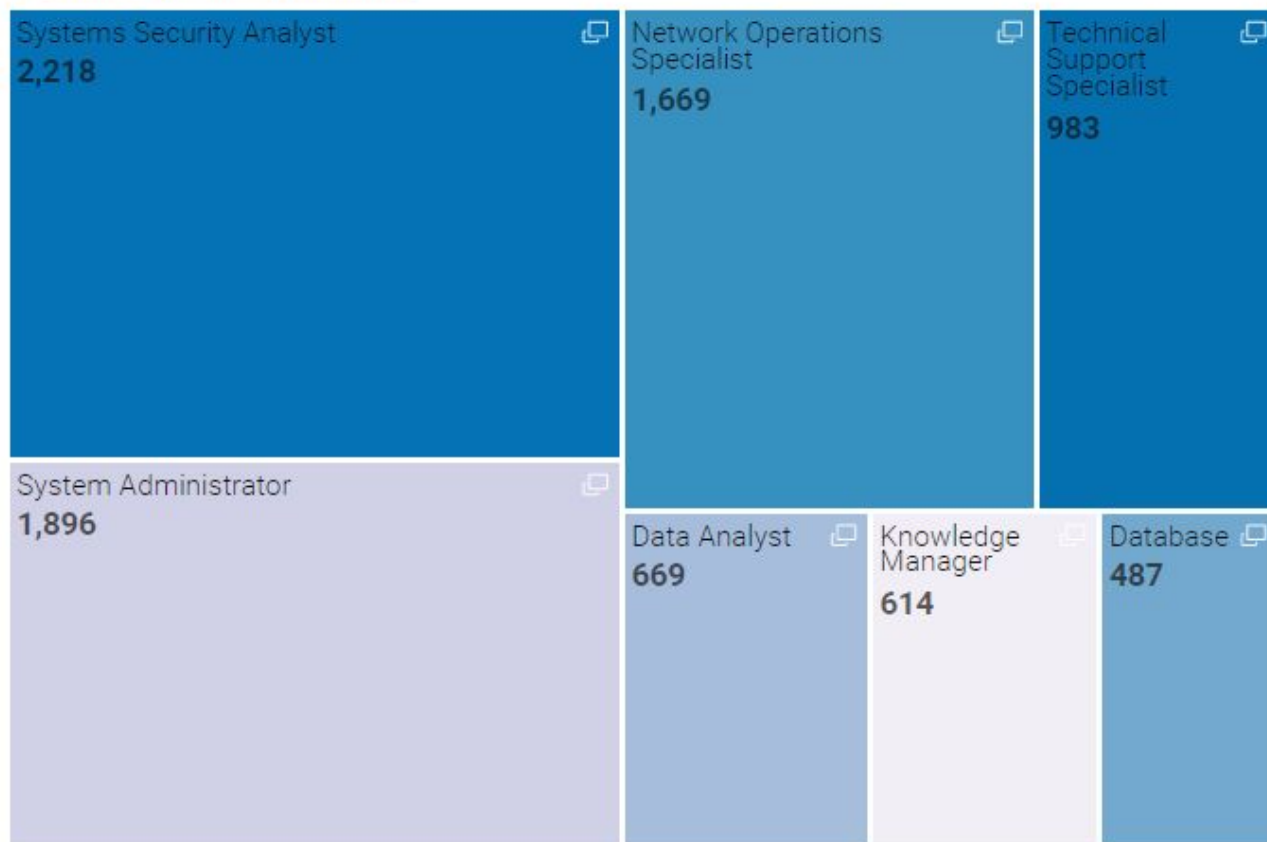

Notes: The NICE Workforce Categories are not mutually exclusive- one job could perform multiple roles within the framework. The data shown here are not intended to be aggregated.

CERTIFICATION HOLDERS / OPENINGS REQUESTING CERTIFICATION ⓘ

■ Certification holders

■ Openings requesting certification

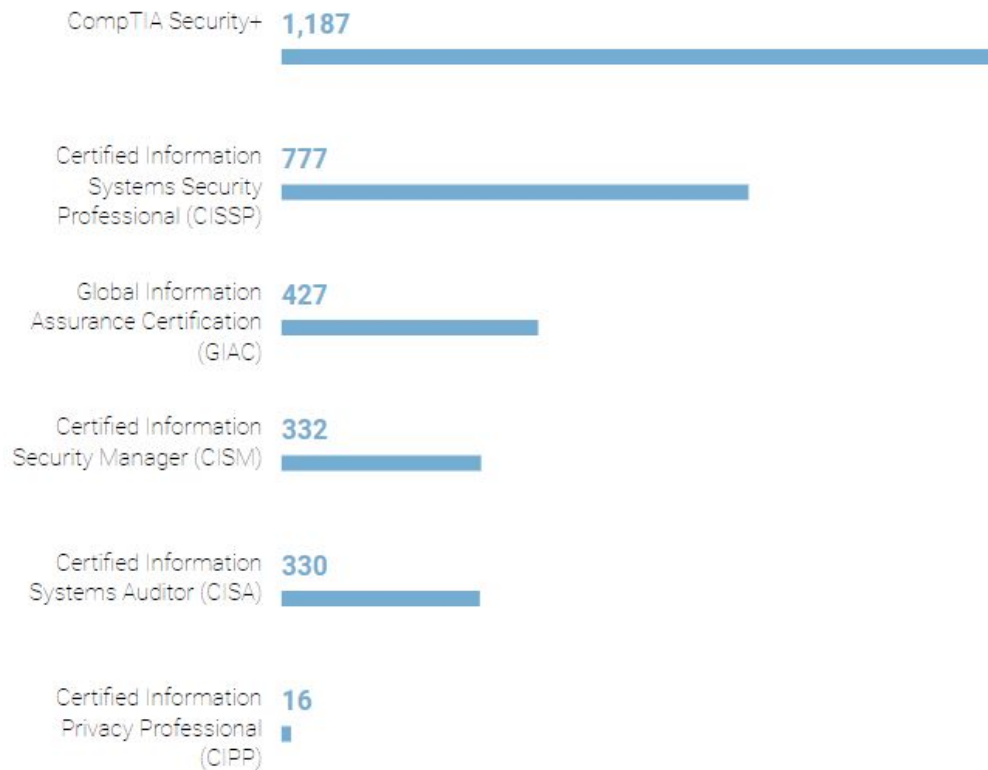



Hawai'i State Department of Education
Ka 'Oihana Ho'ona'auao o ke Aupuni Hawai'i



QUESTIONS? COMMENTS?!

Debasis Bhattacharya, JD, DBA
UH Maui College
debasisb@hawaii.edu
maui.hawaii.edu/cybersecurity